

LOW PRESSURE (LP) ENDOINJECTOR™ INSTALLATION AND OPERATION MANUAL

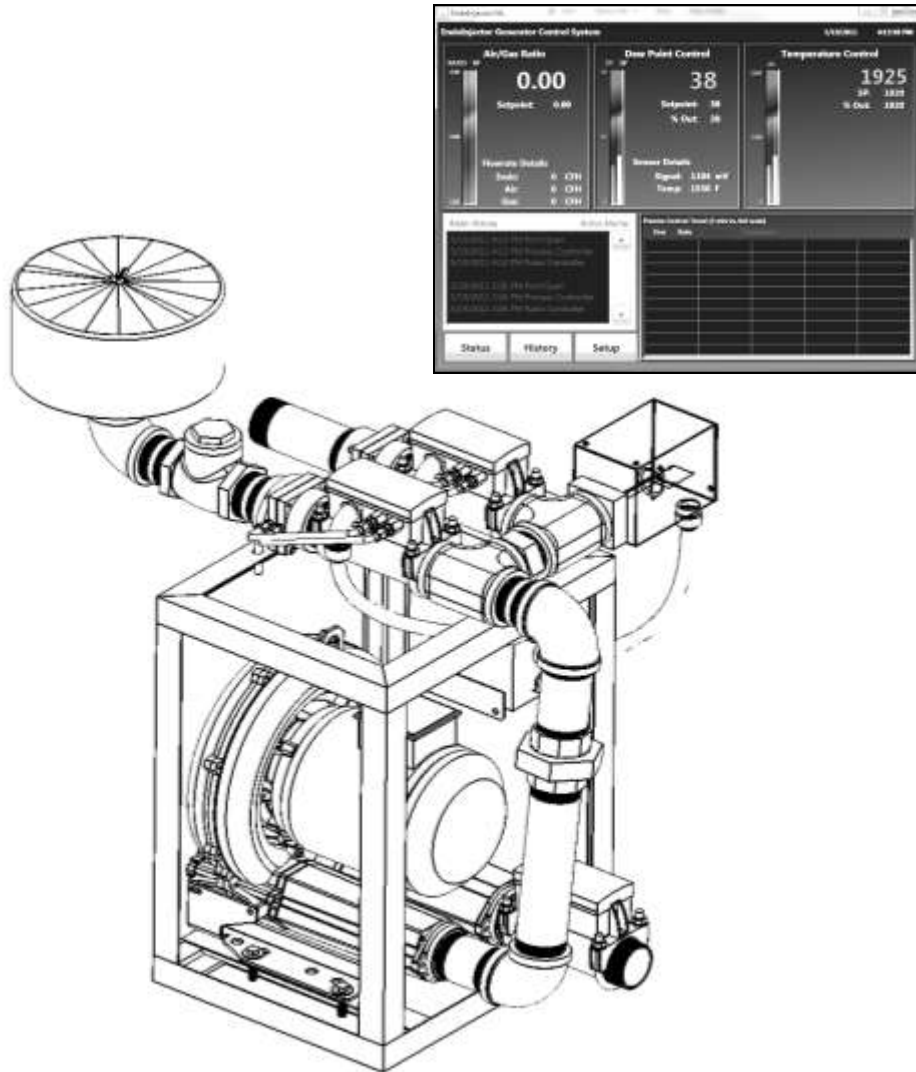

TABLE OF CONTENTS

NOTICE, CAUTIONS, AND WARNINGS 3
EXPRESS WARRANTY ON ATMOSPHERE ENGINEERING EQUIPMENT 4
DESCRIPTION 6
SPECIFICATIONS..... 7
 MODBUS COMMUNICATIONS..... 7
 DATA STORAGE..... 7
MECHANICAL COMPONENT OVERVIEW 8
ELECTRICAL COMPONENT OVERVIEW 9

INSTALLATION

 INSTALLATION NOTICE 10
 MECHANICAL INSTALLATION 10
 ELECTRICAL INSTALLATION 12

SYSTEM OPERATION

 MAIN SCREEN OVERVIEW..... 14
 RATIO CONTROL PANEL 15
 DEW POINT CONTROL PANEL..... 16
 TEMPERATURE CONTROL PANEL..... 17
 PROCESS CONTROL TREND PANEL 17
 ALARM HISTORY PANEL..... 17
 SYSTEM NAVIGATION BUTTONS 18
 SYSTEM SETUP
 SETUP SCREEN OVERVIEW 18
 SETUP SCREEN NAVIGATION BUTTON REVIEW 19
 RATIO SETUP PARAMETERS 20
 DEW POINT SETUP PARAMETERS..... 21
 TEMPERATURE SETUP PARAMETERS 23
 SYSTEM SETUP PARAMETERS 25
 PAPERLESS CHART RECORDER (HISTORY SCREEN)
 PAPERLESS CHART RECORDER OVERVIEW 28
 CHART RECORDER OPERATION..... 29
 ALARM STATUS SCREEN
 CRITICAL ALARMS 29
 NON-CRITICAL ALARMS..... 30
 COMMUNICATION ALARMS..... 20

MAINTENANCE 31

ADDITIONAL DOCUMENTATION

 AIR ORIFICE FLOW METER CALIBRATION
 GAS ORIFICE FLOW METER CALIBRATION
 ASSEMBLY WIRING DIAGRAM
 INSTALLATION WIRING DIAGRAM
 MODBUS ADDRESS LIST

NOTICE, CAUTIONS, AND WARNINGS

NOTICE

This Bulletin contains important safety information and should be read and understood by all individuals who install, operate, or service this equipment.

Failure to follow the precautions and recommendations of this manual may subject personnel and property to dangerous conditions.

WARNING

The valves provided by Atmosphere Engineering are designed to provide precision gas flow control and WILL NOT provide positive gas shut off. Failure to use automatic isolation valves may cause flammable gases to leak into the equipment. Properly rated and regularly inspected gas isolation valves shall be installed regularly and inspected on the gas supply lines feeding Atmosphere Engineering equipment per the guidelines outlined in the National Fire Protection Agency publication NFPA86.

Endothermic Gas contains high concentrations of Carbon Monoxide and other dangerous and flammable gasses that can cause fire, asphyxia, or possible brain damage at elevated levels. It is strongly recommended that generator operators and maintenance personnel ventilate the area surrounding the generator and use carbon monoxide monitors to ensure a safe working environment when working around any endothermic gas generator.

CAUTION

The EndoInjector™ is designed to accurately mix air and gas together and precisely control the mixture ratio to produce high quality endothermic gas. However, setting the air gas ratio outside the recommended values described in this manual could subject personnel and property to dangerous conditions. Only properly trained and experienced personnel shall operate and maintain the EndoInjector™ generator control system.

TECHNICAL ASSISTANCE

Contact Atmosphere Engineering with all questions or concerns regarding the installation, operation, and setup of the EndoInjector™ mixing system.

Atmosphere Engineering Company
4343 South 27th Street
Milwaukee, Wisconsin 53221
United States of America

Phone: 414-331-2457
Fax: 414-332-2457
E-Mail: support@atmoseng.com

EXPRESS WARRANTY ON ATMOSPHERE ENGINEERING EQUIPMENT

ATMOSPHERE ENGINEERING COMPANY (AEC) warrants products for a period of one (1) year from the date of shipment from AEC to the original purchaser to be free from defects in material and workmanship under normal recommended use, service, inspection, and maintenance. Normal recommended use, service, inspection, and maintenance, mean:

1. Not to be used in excess of nor below the rated capacity, pressure, and temperature ranges specified in the applicable quotation, purchase order, acknowledgment, marketing literature, nameplate, specification sheet, or the Installation, Operation, Inspection, and Maintenance Manual (THE MANUAL); and
2. Using only clean gases free of solids and other contaminants not considered constituents of the gas; and
3. Installation, operation, inspection, and maintenance in compliance with THE MANUAL; and
4. The AEC products being used only in:
 - a. Ambient environments lower than 132 °Fahrenheit (54 °Celsius) unless specifically designed and so labeled by AEC for higher temperatures; and
 - b. Non-corrosive environments; and
 - c. Completely protected from moisture, rain, snow, or other outside environments; and
 - d. Not to be used below 32 °Fahrenheit (0 °Celsius) unless precautions are taken for low temperature conditions as shown in THE MANUAL.
5. Being used only for applications permitted by THE MANUAL or other AEC literature or special applications approved in a separate written authorization by AEC.

WARRANTY EXCEPTIONS

This Warranty does not apply to damage caused by any or all of the following circumstances or conditions:

1. Freight damage;
2. Parts, accessories, materials, or components not obtained from nor approved in writing by AEC;
3. Any consequential or incidental damages including but not limited to loss of use, loss of profits, loss of sales, increased costs, arising from the use of any product system or other goods or services manufactured, sold, or provided by AEC;
4. Misapplication, misuse, and failure to follow THE MANUAL or other literature, instructions, or bulletins (including drawings) published or distributed prior to THE MANUAL.

The exclusive remedy under this Warranty or any other express warranty is the repair or replacement without charge for labor and materials of any AEC parts found upon examination by AEC to have been defective. Since certain AEC equipment is heavy, bulky and not deliverable by U.S. mail or other parcel service, AEC equipment may be returned only upon written consent of AEC and then only to the location designated by AEC. Generally such consent will be given only upon the condition that the customer assume and prepay all carrier charges and responsibility for damage in transit.

Purchasers of AEC products, equipment, goods, or services waive subrogation on all items covered under their own or any other insurance.

(CONTINUED ON NEXT PAGE)

EXPRESS WARRANTY ON ATMOSPHERE ENGINEERING EQUIPMENT

(CONTINUED FROM PREVIOUS PAGE)

DISCLAIMER

THIS WARRANTY IS EXCLUSIVE. AEC EXPRESSLY DISCLAIMS ANY AND ALL OTHER WARRANTIES WHETHER EXPRESS OR IMPLIED INCLUDING ANY IMPLIED WARRANTY OF MERCHANTABILITY OR FITNESS FOR A PARTICULAR PURPOSE OR ANY PURPOSE.

No person, including dealer, seller, or other representative of AEC is authorized to make, on behalf of AEC, any representations beyond those contained in AEC literature and documents or to assume for AEC any obligations or duties not contained in this Warranty and Warranty Policy.

AEC reserves the right to make design and other changes, modifications or improvements to products, services, literature, or systems, without any obligation, to furnish or install same on any previously sold or delivered products or systems.

LIMITATION OF LIABILITY

It is expressly agreed that the liability of AEC is limited and AEC does not function as an insurer. The purchaser and/or user agree that AEC is not liable for loss, harm, or damage due directly or indirectly to any occurrence or consequences there from. If AEC should be found liable to anyone on any theory (except any express warranty where the remedy is set forth in Section 2 of this Warranty and Warranty Policy) for loss harm or damage, the liability of AEC shall be limited to the lesser of the actual loss, harm or damage or the purchase price of the involved AEC equipment or service when sold (or when service performed) by AEC to customer. This liability is exclusive and regardless of cause or origin resulting directly or indirectly to any person or property from:

1. The performance or nonperformance of any obligations set forth in this Warranty and Warranty Policy;
2. Any agreement including specifications between AEC and the customer;
3. Negligence, active, passive or otherwise of AEC or any of agents or employees;
4. Breach of any judicially imposed warranty or covenant of workmanship, durability or performance; and
5. Misrepresentation (under the Restatement, common law or otherwise) and/or strict liability involvement;
6. Liability for fraud-in-the-inducement.

WARRANTY FIELD SERVICE

If Warranty Field Service is rendered at the request of the purchaser or user and the difficulty is found not to be with AEC's product, the purchaser shall pay the time and expense (at the prevailing rate at the time of the service) of AEC's field representative(s). Charges for service, labor, and other expenses that have been incurred by the purchaser, customer, or agent without written approval of AEC will not be accepted. The OEM or other reseller is responsible for transmitting installation and operating instructions, THE MANUAL or other service literature supplied by AEC with the equipment.

(END OF WARRANTY TEXT)

DESCRIPTION

Mixing System

The EndoInjector™ is a precision gas mixing system and endothermic gas generator control system integrated into one package. The patented EndoInjector™ mixing system designed by Atmosphere Engineering utilizes electronic flow measurement and a precision gas injection valve to constantly monitor and control the ideal gas mixture required to generate high quality endothermic gas.

The EndoInjector™ incorporates the latest technology in regenerative blower design that is capable of significant turndown for single and multi-retort generators. When combined with the patented mixing system, the EndoInjector™ delivers flow on demand throughout the working range of any generator down to 20% of rated capacity. This feature eliminates endothermic gas waste during production while maintaining the precise gas mixture and ratio adjustment capability required to control gas quality throughout the turndown range.

Dew Point Control

The integrated dew point control logic of the EndoInjector™ will monitor the endothermic gas quality then precisely modify the air gas mixture to control the quality of the endothermic gas. The sensor required to monitor this gas is not included with the EndoInjector system but can be purchased separately from Atmosphere Engineering.

Temperature Control

The integrated temperature control logic of the EndoInjector™ will monitor a single temperature zone or multiple temperature zones and provides an output (relay or signal) that can be used to accurately control the temperature of any endothermic gas generator. The thermocouple required to monitor temperature and valves required to control temperature are not included with the EndoInjector™ system but can be purchased separately from Atmosphere Engineering.

Paperless Chart Recorder

The EndoInjector™ integrates a full-color touch-screen paperless chart recorder to monitor all critical process variables of an endothermic gas generator. The data and backup files are stored and maintained on the touch-screen in an encrypted format for a period of 5+ years. The data can be exported to CSV format for easy review within a spreadsheet application (i.e. MS Excel or similar).

Custom Designed System

The EndoInjector™ is a precision mixing system that is assembled, calibrated, and fully tested to perform to the exact requirements of a specific endothermic gas generator. The system is not designed to be interchangeable with any other generator without written approval of the new generator application by Atmosphere Engineering.

SPECIFICATIONS

Maximum Flow Capability Calibrated to Order – Indicated on Serial Tag
Minimum Flow Range..... 20% of Maximum Flow
Temperature Limits..... 32°F to 130°F
Flow Meter Pressure Limits 5 psig maximum
Inlet Gas Supply Pressure 0.25 - 3 psig (min-max)
Control Power Required..... 85-264VAC (50/60 HZ)

Horsepower..... 1.25 HP
Power Supply 3 Phase 230/460 VAC 50/60 Hz
Power Required 0.93 kW

Horsepower..... 3.50 HP
Power Supply 3 Phase 230/460 VAC 50/60 Hz
Power Required 2.55 kW

MODBUS COMMUNICATION

Communication with the control system is handled via ModbusRTU (RS232 or RS485) or ModbusTCP/IP (Ethernet) as required. The typical installation utilizes a serial communication link between the COM port on the touch-screen and the RS232 port on the control system. This leaves the Ethernet and RS485 ports available for additional connections to a SCADA system in the facility.

DATA STORAGE

The HMI touchscreen includes a minimum of 7GB of unused internal hard drive space. The EndoInjector™ daily encrypted log files are contained within the AEC log directory and a backup file is located in a backup directory. The combined daily file size will consume approximately 300KB per day. Therefore, the actual capacity of the hard drive will be able to maintain over 60 years of log data. However, due to memory life considerations the process log data integrity should be considered maintained for a period of 5+ years. Of course, the actual data may last longer and can be backed up remotely for an indefinite period.

MECHANICAL COMPONENT OVERVIEW

The Endolinjector mixing system contains many individual components that are preassembled, calibrated, and fully tested to perform as a complete system. The diagram(s) below detail the critical mechanical components of the system.

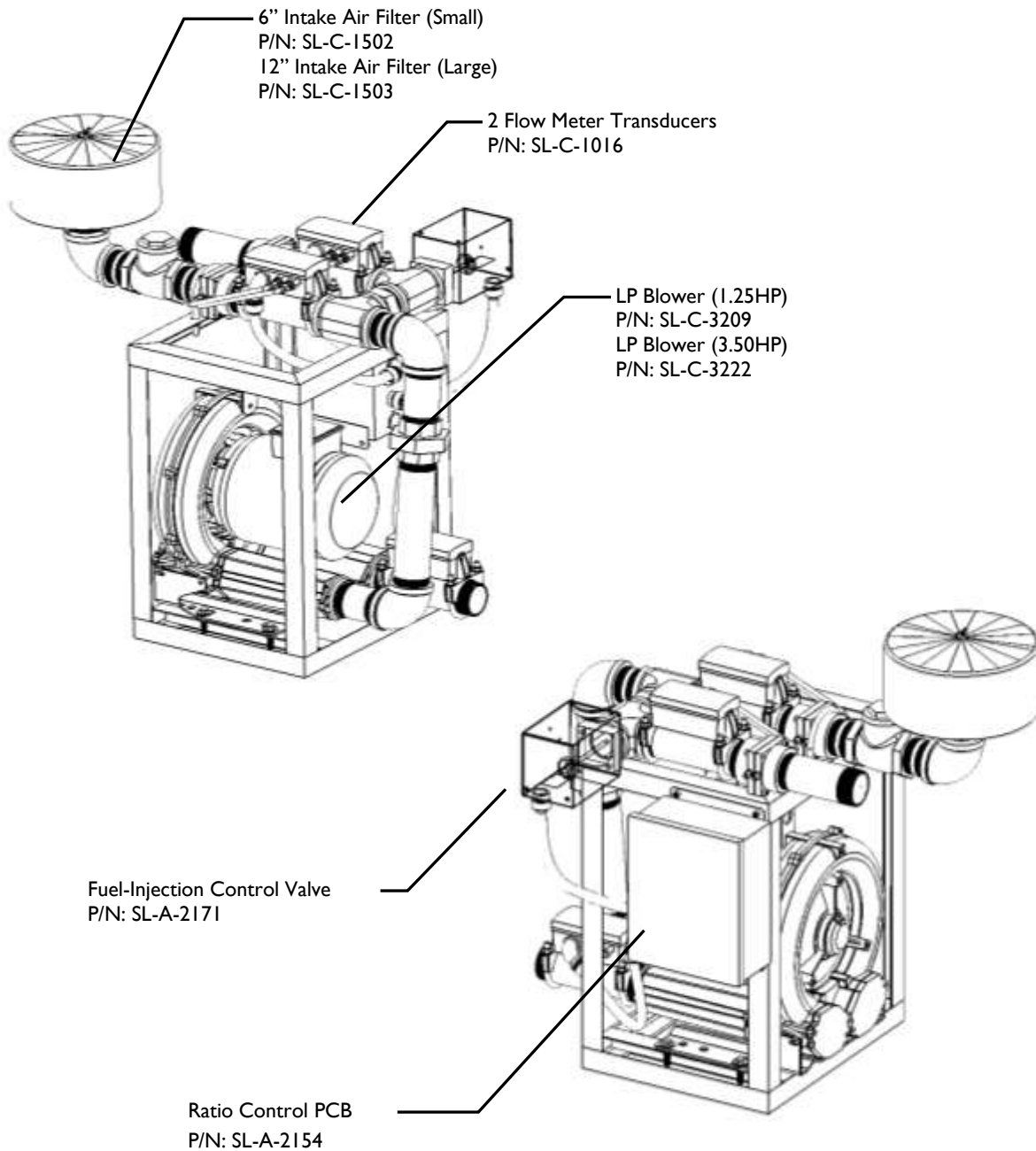

ELECTRICAL COMPONENT OVERVIEW

The LP EndoInjector™ mixing system has been designed to work with many different types of controller options depending on customer specifications and specific generator control requirements. Refer to the electrical wiring diagram and material list attached to this manual for any system specific components. The electrical components are typically packaged separately and found in a box that accompanies the mixing system. The standard EndoInjector system components (unless otherwise specified) include the following items.

1. 24VDC Power Supply (P/N: SL-E-1698)
2. 10" WINXP Touch-screen (P/N: SL-E-1982-ENDC)
3. Dew Point / Temperature Dual Loop 9200 Controller (P/N: SL-E-1694)
4. (5) 24VDC Relay (4 contact) with Bases (Relay P/N: SL-E-1869, Base P/N: SL-E-2257)
5. Serial Communication Cable

(THE REST OF THIS PAGE HAS BEEN LEFT BLANK)

INSTALLATION NOTICE

The LP EndoInjector™ mechanical mixing system comes preassembled and ready for installation onto an endothermic gas generator. Only qualified personnel experienced with endothermic gas generator operation and safety requirements shall perform an EndoInjector installation. It should be noted that additional mechanical components and interlocks will be required other than those supplied with the LP EndoInjector™ mixing and control system to ensure the generator is safe and meets NFPA 86 guidelines.

MECHANICAL INSTALLATION

The LP EndoInjector™ is a robust industrial device however; some precision measurement components may be susceptible to damage from severe shock. Care should be taken to handle the system during the installation process. The system was not designed to support personnel and should not be used as a step or a support as this could damage components on the system.

Installation Procedure (Refer to pipeline diagram attached to manual for proper installation)

1. Inspect the mixing system for any damaged or missing components and confirm each component detailed in the “Mechanical Component Review” section of this manual.
2. Make note of the following locations on the mixing system and consider the best location for the mixing system on the generator to accommodate the piping and access requirements to reach these locations:
 - a. Gas Supply Inlet
 - b. Mixed Gas Outlet
 - c. Air Intake Filter
 - d. Air Relief Valve
3. Secure the mixing system to the generator frame using mounting holes on the base of the system. If retrofitting a generator, the old blower motor location is typically a suitable location. The mixing system should be mounted level and should be reasonably insulated from direct radiant heat sources.
4. Attach the reaction gas supply pipeline to the gas inlet on the mixing system. The gas supply must be pressure regulated to a minimum of 0.5 psig and a maximum of 3 psig. Note that the reaction gas piping must contain the required interlocks and components to meet NFPA 86.
5. Attach the mixed gas outlet to an appropriate automatic fire check valve and install a low pressure air switch to confirm blower operation.
6. Install the Outlet Pressure Transducer to a sense line attached to the generator outlet (after the cooler(s) but before any valves).
7. Install Air Intake Filter.

MECHANICAL INSTALLATION

(CONTINUED FROM PREVIOUS PAGE)

The following connections shall be made as described.

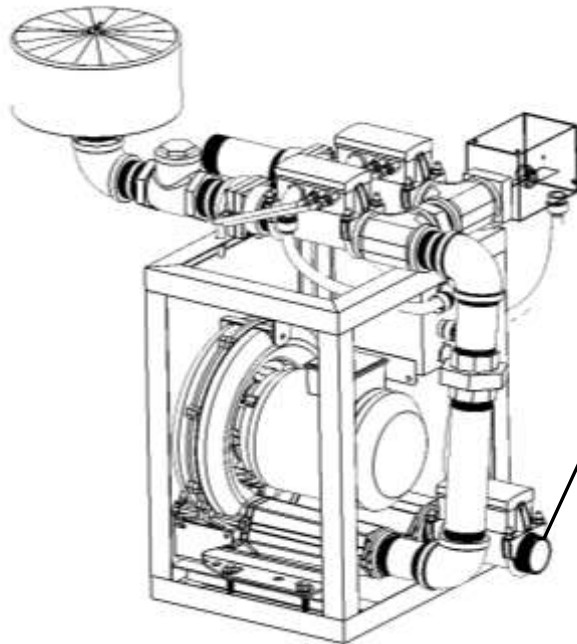

Mixing System Outlet
(Typical: 2" NPT Female)

This is mixing system outlet that should be piped to fire check valve with low pressure switch to confirm blower operation before gas is enabled.

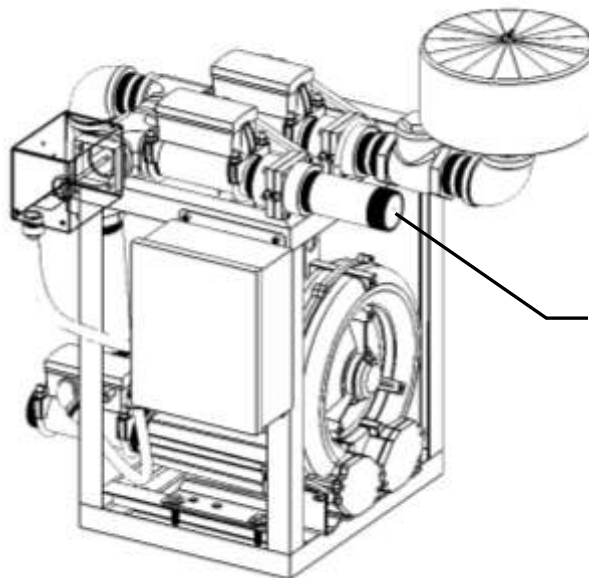

Air Intake Filter
(6" Style Pictured)

Access to this point is required to change filter when required.

Gas Supply Inlet
(Typical: 2" Male)

Properly regulated and interlocked reaction gas supply pipeline with automatic gas safety shutoff and pressure switches should supply reaction gas here.

ELECTRICAL INSTALLATION

It is important to note that there are many different generator manufacturers and the wiring designs and control logic can be very different depending on the manufacturer and age of the generator. Only a qualified electrician experienced with endothermic gas generator operation and current safety requirements shall perform an EndoInjector installation. Proper safe electrical interlocks must be designed to meet safe generator operation based on NFPA86 guidelines. If necessary, installation supervision and direction of turnkey installation services are available from Atmosphere Engineering or an AEC certified installation professional. The primary consideration is that the EndoInjector™ control system is designed to provide the temperature control, dew point control, and air gas ratio control of an endothermic gas generator. Basic electrical installation includes:

1. Mount the industrial touch-screen supplied with the system into generator control enclosure and ensure the screen is protected from close proximity to direct radiant heat sources or other excessive heat. Ensure proper cutout and do not force into cutout or over tighten mounting brackets as it may deform the touch-screen and cause the touch panel to malfunction.

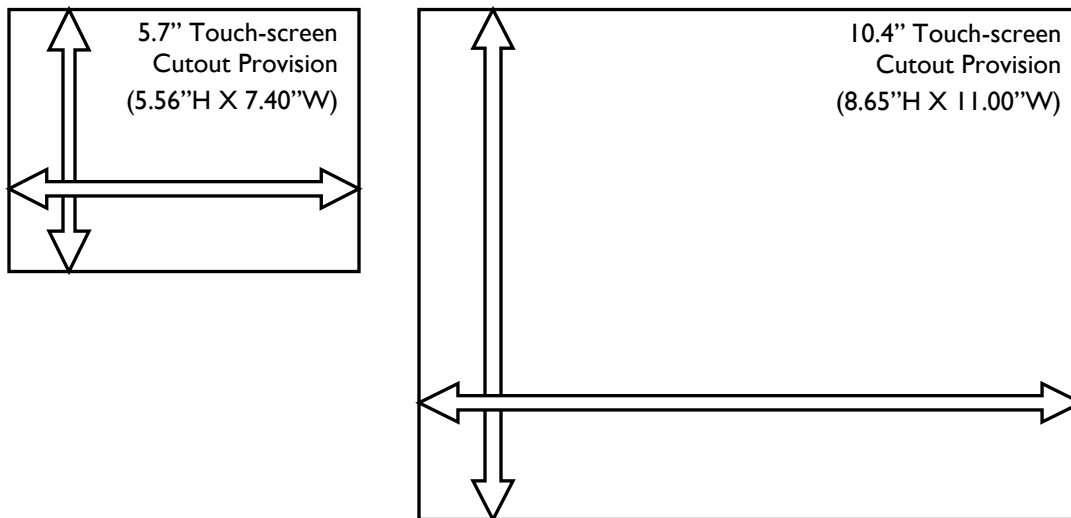

2. Mount the 24VDC power supply, process controller, and relays supplied with the EndoInjector™ system inside the controls enclosure. If retrofitting to existing generator it is typical to remove temperature and dew point controllers installed on generator. However, it is important to make detailed notes of wiring numbers and their purpose so that final terminations can be made with the EndoInjector™ control system.
3. Wire the high voltage EndoInjector™ blower motor.
✎ **IMPORTANT** ✎
Make sure to check the terminal jumpers inside the motor wiring box and confirm they are positioned properly for the voltage being supplied. (Note: To reduce electrical noise in the DC circuits, it is recommended that the high voltage motor wiring should be conveyed through a separate conduit from the low voltage control wiring.)

ELECTRICAL INSTALLATION

(CONTINUED FROM PREVIOUS PAGE)

4. Wire the mixing system control components together as shown on the attached installation wiring diagram. This wiring diagram only details the control system assembly and integration between mixing system, HMI, and sensor. The wiring diagram does not detail the required integration wiring between the control system and the generator panel and components. This is because the integration wiring and wire numbers will be dependent on the mfg and age of the generator equipment. It is important to have a detailed wiring diagram of the generator to use as a guide to locate wire numbers and terminal locations required for proper EndoInjector™ installation and safe generator operation. After the wiring detailed on the attached installation diagram is completed, review the following check list as a guide to ensure proper integration of the relays and control outputs are made to the generator.
 - a. **Low Temperature Alarm:** The low temperature alarm relay is only energized when the generator temperature is high enough to safely start the mixing system. A normally open contact on this relay should be used in the motor starter circuit to ensure the temperature is safe before the EndoInjector™ mixing system can be allowed to start.
 - b. **Critical Alarm Relay:** The critical alarm relay is only energized when all internal checks and ratio control system confirms system is ok to start. If there is a critical failure this relay will be de-energized. Therefore, it is typical to wire a normally open contact on this relay in series with the low temperature alarm relay. This relay is specific to the EndoInjector™ system and will not be part of existing generator wiring.
 - c. **Temperature Control Output:** The EndoInjector™ provides both a relay for time proportional control and a 4-20mA signal output for heat control. Either of these outputs can be used to integrate existing heat control components to control the temperature of the generator. The time proportional relay energizes when calling for more heat. The 4-20mA signal increases when calling for more heat.
 - d. **Non-Critical Alarm:** The Non-Critical alarm relay is simply a deviation alarm relay that will energize when a temperature, dew point, or ratio deviation alarm occurs. The relay will only de-energize when all deviation alarms are ok. Therefore, a horn silence circuit will be required if using this relay to sound a horn.
 - e. **Probe Burnout Relay:** The probe burnout relay energizes when requesting a zirconia probe to perform a burnout cycle. The relay will remain energized during the entire probe burnout time (see operation for setting) and then de-energize until the next probe burnout.
 - f. **Dew Point Wiring:** When using a zirconia oxygen sensor to monitor dew point, be sure to wire both the thermocouple and mV signal wire to the controller as detailed on the wiring diagram.
 - g. **Temperature Control Wire:** A thermocouple (Typically: K or S Type) should be wired to the temperature control input of the EndoInjector controller™. Note that the control thermocouple must be separate from the over temperature thermocouple.

SYSTEM OPERATION

A generator fitted with the EndoInjector™ mixing and generator control system is designed to start and stop the same as a gas generator with a mechanical mixing system. However, the patented advanced control logic and operator interface of the EndoInjector™ mixing system are designed to provide complete monitoring and control of all critical generator variables with an integrated paperless chart recorder to log the generator performance.

MAIN SCREEN OVERVIEW

The full-color touch-screen provides the main interface between an operator and the EndoInjector™ control system. The EndoInjector™ software is designed to run on any computer operating Microsoft operating system (XP or later) with the .net3.5SP1 Framework or later installed.

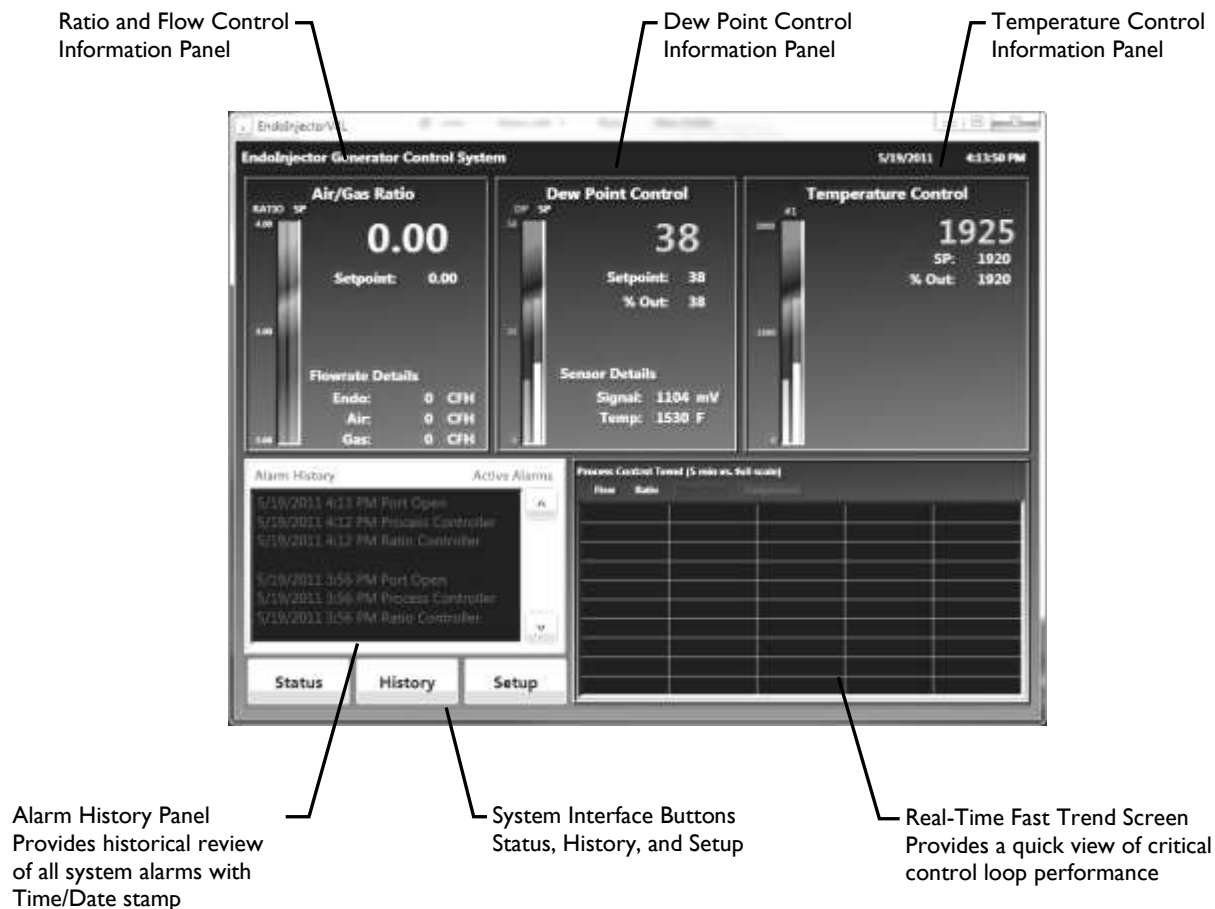

RATIO AND FLOW CONTROL PANEL

The ratio and flow control panel provides detailed information regarding the mixing system operation. Note: The bar graph scales are dependent on the pen scales defined within the paperless chart recorder and can be changed using the “edit pen” button on the history screen.

Air/Gas Ratio

The Air/Gas Ratio value is the currently measured air flow divided by the currently measured gas flow passing through the mixing system. This value represents the actual mixture of air and gas being introduced into the gas generator and is directly correlated to the dew point of the endothermic gas produced. The actual ratio is controlled to the “Ratio Setpoint” by the fuel-injection control valve. It should be understood that a higher ratio will produce endothermic gas with a higher dew point.

Ratio Setpoint

The Ratio setpoint is the desired mixture of air and gas that should be introduced into the generator. This value can be entered manually or can be controlled automatically by the dew point PID loop output. When controlled automatically, the operator must provide a minimum and maximum ratio setpoint so that the dew point control loop can only change the loop by a limited range.

Endo Flow

The “Endo” flow value is a calculated value that represents the amount of endothermic gas being produced by the generator. It is calculated using the following equation:

$$\text{Endo Flow} = (\text{Air Flow} + \text{Gas Flow}) \times (\text{Expansion Factor})$$

Air Flow

The air flow is the actual calibrated measurement of air passing through the EndoInjector mixing system. This value is measured using the air flow transducer mounted to the mixing system. A calibration curve detailing the transducer performance in relation to the factory calibrated flow measurements is attached to this manual. The air flow meter has integrated test ports that can be used to certify the meter calibration while in operation.

Gas Flow

The gas flow is the actual calibrated measurement of gas passing through the EndoInjector mixing system. This value is measured using the gas flow transducer mounted to the mixing system. A calibration curve detailing the transducer performance in relation to the factory calibrated flow measurements is attached to this manual. The gas flow meter has integrated test ports that can be used to certify the meter calibration while in operation.

DEW POINT CONTROL PANEL

The dew point control panel provides detailed information regarding the quality of the endothermic gas being produced by the gas generator. Note: The bar graph scales are dependent on the pen scales defined within the paperless chart recorder and can be changed using the “edit pen” button on the history screen.

Dew Point

The main dew point value is the actual dew point of the endothermic gas being produced. The dew point is typically measured by taking a sample of endothermic gas and introducing it to a zirconia oxygen sensor. By measuring the residual oxygen content in the sample and the temperature of the gas sample the actual dew point can be calculated. This value can be checked using a portable dew point analyzer and then offset if needed by adjusting the “H Factor” located in the “Dew Point Setup” screen.

Notably, some generators utilize an actual dew point sensor instead of a zirconia sensor. The EndoInjector controller can be setup to control using this sensor but it should be noted that a dew point value measured in this way can not be offset using an “H Factor” variable and must rather be adjusted using the “Sensor Zero/Sensor Span” parameters.

Dew Point Setpoint

The dew point setpoint is the desired dew point that should be produced by the endothermic gas generator. This value is typically entered manually by the operator. The dew point of endothermic gas is directly correlated to the resulting “%Carbon” level within a heat treating furnace. While the dew point will not exactly predict %Carbon inside a furnace, because there are many other variables that determine the %Carbon value in a heat treating furnace, but generally a higher dew point will result in a lower %Carbon value inside a heat treating furnace (all other furnace variables being equal).

%Output

The %Output value represents the PID control output signal used to change the air/gas ratio setpoint. If the %Output is equal to 100% then the air/gas ratio setpoint will be equal to the maximum air/gas ratio setpoint provided by the operator. If the %Output is equal to 0% then the air/gas ratio setpoint will be equal to the minimum air/gas ratio setpoint. The corresponding values between 0-100% will result in a linear change to the air/gas ratio setpoint.

Probe mV

The probe mV is the actual measured signal from the dew point sensor. This value is used to determine the dew point of the endothermic gas sample.

Probe Temperature

The probe temperature is the actual measured temperature of the gas sample within the dew point sensor. This value is used to determine the dew point of the endothermic gas sample. Note: The ideal temperature of a zirconia sensor during operation is 1550degF.

TEMPERATURE CONTROL PANEL

The temperature control panel provides detailed information regarding the temperature of the endothermic gas generator. The temperature panel is expandable to 3 separate temperature control loops that can be simultaneously viewed within this panel. Note: The bar graph scales are dependent on the pen scales defined within the paperless chart recorder and can be changed using the “edit pen” button on the history screen.

Temperature

The temperature value is the actual temperature within the hot zone of an endothermic gas generator. This value is measured by an industrial thermocouple. Note: a value of 9999 means that there is an open loop on the thermocouple input and the thermocouple is either not wired correctly or has failed.

Temperature Setpoint

The temperature setpoint is the desired temperature within the hot zone of an endothermic gas generator. This value is typically set by the generator operator to a value of 1900degF or 1950degF for normal generator operation.

%Output

The %output value represents the PID control output signal used to control the temperature of the generator. The actual output can be either a time proportional (relay type) control or a 4-20mA control signal. If the temperature is lower than the temperature setpoint then the %output will increase. The increase in %output will result in the temperature control relay being energized “more often” and also result in the 4-20mA signal to increase in current.

PROCESS CONTROL TREND PANEL

The process control trend panel is updated every second to display actual control characteristics of the mixing system that might not be seen on the longer 1 minute storage interval of the historical log found in the paperless chart recorder. The trend panel is not the same as the paperless chart recorder in that all the data is updated much more quickly (1 second intervals) and the trend data is not stored longer than 5 minutes. The primary function of the trend panel is to provide real time feedback of system operation to better tune and confirm minimal control oscillations during system operation.

Note: The trend pen scaling is dependent on the pen scales defined within the paperless chart recorder and can be changed using the “edit pen” button on the history screen.

ALARM HISTORY PANEL

The alarm history panel details the exact time and date of the last 100 alarms registered by the EndoInjector™ control system. The panel provides a historical log so that alarms that occur while operators are not directly monitoring the gas generator can be later examined.

SYSTEM INTERFACE BUTTONS

Setup Button

The “Setup Button” is used to access the system setup screen. It should be noted that all system parameters are password protected with 2 levels of security to ensure accidental parameter changes cannot occur unless the operator is actually logged in.

History Button

The “History Button” is used to access the paperless chart recorder.

Status Button

The “Status Button” is used to view active system alarms and communications status.

System Setup Screen Overview

The setup panel organizes all setup parameters into specific groups. These groups are accessed using the “Parameter Group” buttons located at the top of the setup screen. It should be noted that all parameters are password protected to provide “READ ONLY” access to control parameters. Some of the buttons detailed below will not be available unless logged in as “ADMIN”.

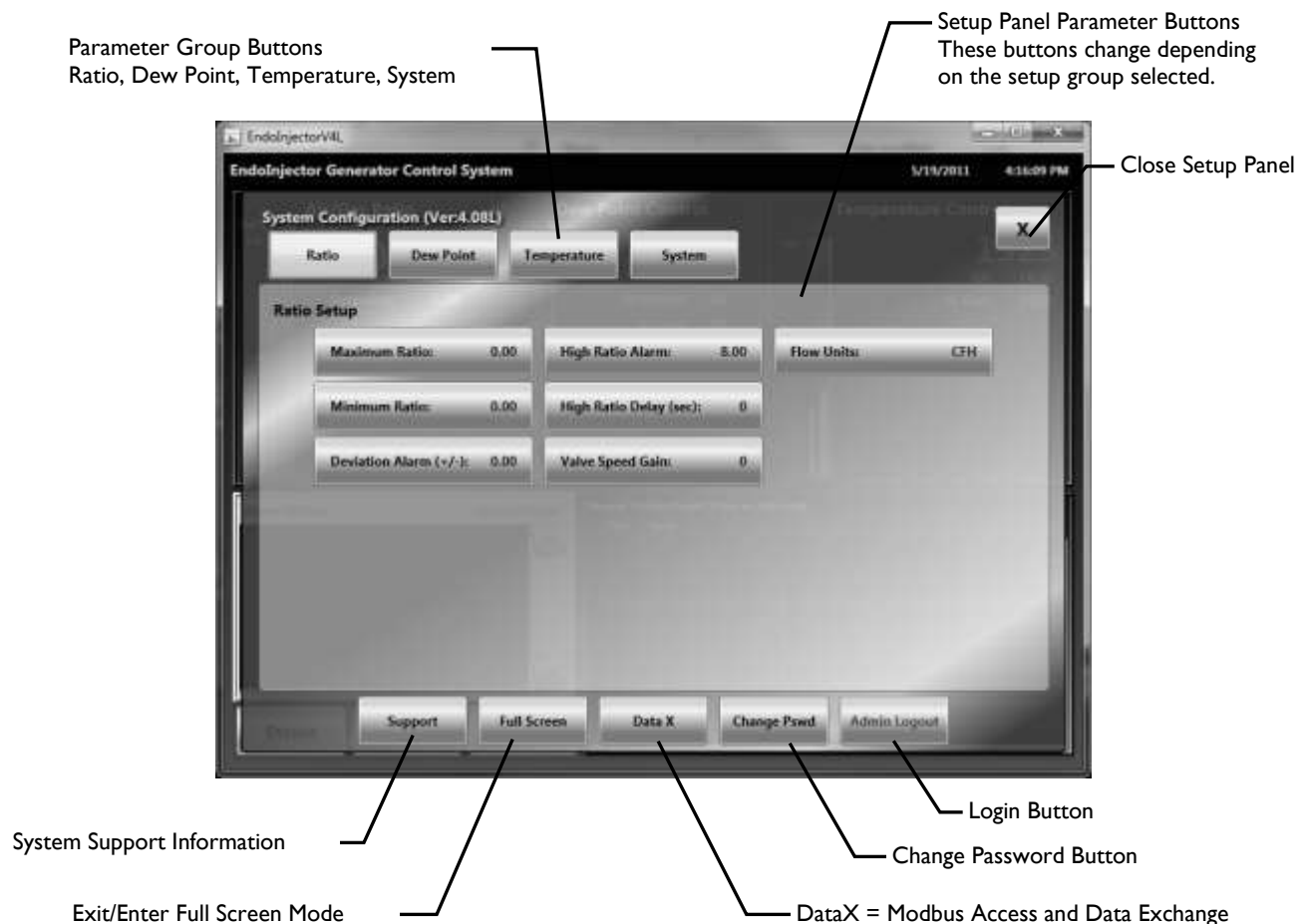

SYSTEM SETUP SCREEN MAIN BUTTONS

Ratio Button *(not protected)*

The ratio button provides access to the parameters involved in the setup and control of the air gas mixing system.

Dew Point Button *(not protected)*

The dew point button provides access to the parameters required to setup the endothermic gas dew point control loop.

Temperature *(not protected)*

The temperature button provides access to the parameters required to setup the temperature control of the generator.

System Button *(ADMIN Level Only)*

The system button provides access to the main system configuration parameters. These parameters are critical to the operation of the generator and only accessible in ADMIN level.

Support Button *(not protected)*

The support button opens a panel that provides contact information for the support of the EndoInjector™ mixing system.

Full Screen Button *(ADMIN Level Only)*

The full screen button provide access to the XP operating system desktop. Only available in ADMIN level.

DataX Button *(ADMIN Level Only)*

The DataX button opens a “data exchange” panel that allows direct read/write access to the Modbus registers of the controller. The Modbus register list is attached to this manual. However, it is strongly recommended to contact Atmosphere Engineering before making any changes to the Modbus register values directly. Never change a modus register without knowing what the value is responsible for. Changing values without knowing what each register is responsible for can cause major problems and possibly unsafe situations to occur.

Change Pswd Button *(USER and ADMIN Levels)*

The Change Pswd button will prompt the person logged in to enter a new password for the level currently logged in. For example, if logged in as a USER then the new password will be assigned as the new USER password.

Login Button *(not protected)*

The login button will prompt the operator to enter a password to access either the USER or ADMIN level of parameters. The default passwords are “as shipped” but can be customized using the “Change Pswd” button that appears when logged in.

USER Default Password = 2
ADMIN Default Password = 22

RATIO SETUP PARAMETERS (USER and ADMIN Levels)

These parameters define the control of the air/gas mixing function of the EndoInjector. Changes to these parameters will take effect immediately. All parameters are only editable in USER and ADMIN levels.

Maximum Ratio Set Point (Default = 3.00)

Maximum Air/Gas Ratio to be introduced when dew point control output is equal to 100%. The default setting of 3.00 may differ slightly due to specific generator characteristics. If the dew point is too low and the trim signal is 100% then the Maximum Ratio Set Point should be increased to provide proper dew point control. NOTE: Do not set this value above 3.50 as excessive water vapor may be produced within the generator retorts. If the required air/gas ratio approaches 3.50 this could indicate a probe sensor failure or “sooting” of the catalyst within the retort. Consult the generator manual for troubleshooting guidelines or contact Atmosphere Engineering for further support.

Minimum Ratio Set Point (Default = 2.50)

Minimum Air/Gas Ratio to be introduced when dew point control output is equal to 0%. The default setting of 2.50 may differ slightly due to specific generator characteristics. If the dew point is too high and the trim signal is 0% then the Minimum Ratio Set Point can be decreased to provide proper dew point control. NOTE: Do not set this value below 2.00 as excessive “sooting” may occur within the generator retorts. If the required air/gas ratio approaches 2.00 this could indicate a probe sensor failure or water collection within the gas sample line. Consult the generator manual for troubleshooting guidelines or contact Atmosphere Engineering for further support.

Ratio Deviation Alarm (Default = 0.10)

This value defines the limit for the ratio deviation alarm. When the actual air/gas ratio deviates from the ratio setpoint by more than this value a Ratio Deviation Alarm will occur.

High Ratio Alarm (Default = 8.0 Nat Gas, 15.0 for Propane Systems)

This value defines the maximum ratio limit that is considered safe. If the actual ratio is higher than this for longer than the high ratio alarm delay, then the critical alarm relay will be de-energized which should be interlocked to stop the mixing system. This is a test to ensure that gas supply is provided and the ratio control valve is functioning.

High Ratio Alarm Delay (sec) (Default = 10 seconds)

The high ratio alarm delay is the amount of time in seconds that a high ratio situation should be allowed to occur before triggering the critical alarm. Note: Depending on the reaction gas supply pipeline, there is typically a few seconds of time that the blower is started before gas is supplied to the mixing system. It may be necessary to increase this delay parameter to accommodate slower reaction gas introduction.

Valve Speed Gain (FACTORY SET = DO NOT CHANGE THIS VALUE)

This value defines the response characteristics of the fuel injection control valve. Typically, once this value is set at the factory, it will not require adjustment.

Flow Units (CFH or M3H)

The flow units button will change the flow measurements and calculation units. This change only occurs in the HMI and will not affect system control characteristics. However, the values stored in the history log files will change depending on this parameter.

DEW POINT SETUP PARAMETERS (USER and ADMIN Levels)

These parameters define the characteristics of the dew point control for the gas being produced by the gas generator. Changes to these parameters will take effect immediately. All parameters are only editable in USER and ADMIN levels.

Dew Point Setpoint

The dew point setpoint is the desired dew point of the generated endothermic gas.

Deviation Alarm (+/-)

The deviation alarm value determines when a dew point deviation alarm should be triggered.

H Factor

The H Factor parameter is used to calibrate the dew point value calculation for zirconia oxygen sensors. Increasing the H Factor by 10 will cause approximately a 1 degF offset in the dew point reading.

Control Mode (Auto/Manual)

The control mode defines the PID control active status for the dew point control loop. Typically this parameter is left in "AUTO" mode but can be changed to "Manual" mode during system startup to "lock" ratio control at one ratio setpoint to season catalyst or lean out generator.

Control Output (%)

The control output in the dew point setup panel is the same as the %output as detailed on the dew point detail panel on the main screen. The value is READ ONLY when dew point PID control is in AUTO mode. However, the %Output can be changed when PID is in MANUAL mode.

Control Setup (P) (Default = 80.0)

The proportional term delivers an output which is proportional to the size of the error signal. In simple terms, the larger the P value is the slower the dew point PID will respond to dew point changes.

Control Setup (I) (Default = 1.00)

The integral term removes steady state control offset by ramping the trim output up or down in proportion to the amplitude and duration of the error signal. This value must be set longer than the time constant of the dew point control process to avoid dew point oscillations. In simple terms, the larger the I value the slower the dew point PD will respond to dew point changes.

Control Setup (D) (Default = 0.00)

The derivative term is proportional to the rate of change of the dew point value. It is used to prevent overshoot and undershoot of the setpoint by introducing an anticipatory action. In simple terms, a small D value might be necessary on generator control to correct a PID that is not controlling well at all. However, in 95% of generator installations, a D value is typically not necessary.

Dew Point Units (F or C)

The dew point units button will change the dew point measurements and calculation units. This change only occurs in the HMI and will not affect system control characteristics. However, the values stored in the history log files will change depending on this parameter.

DEW POINT SETUP PARAMETERS (USER and ADMIN Levels)

(CONTINUED FROM PREVIOUS PAGE)

Probe BO Int (min)

The amount of time between burnout times for zirconia probes. Endothermic gas generator applications typically only require a probe burnout once every day (1440 minutes). (Note: Probe burnout hardware not included with EndoInjector™, sold separately)

Probe BO Time (sec)

The amount of time that air should be introduced into the zirconia probe to burnout any carbon soot collected in the probe. During this time the dew point process value will be held constant. Normal burnout time for a probe is 60 seconds. (Note: Probe burnout hardware not included with EndoInjector™, sold separately)

Probe BO Delay (sec)

The amount of time to wait after the burnout air has stopped before using the probe signals to calculate dew point again. Normal delay time is 120 seconds.

Probe BO Start

The probe BO Start button will initiate a probe burnout immediately. The Probe BO interval timer will also be reset at that time as well.

(THE REST OF THIS PAGE HAS BEEN LEFT BLANK)

TEMPERATURE SETUP PARAMETERS (USER and ADMIN Levels)

These parameters define the characteristics of the temperature control for the gas generator. Changes to these parameters will take effect immediately. Note, if multiple temperature control loops are enabled then temperature loop id buttons will appear at the bottom of the temperature setpoint panel. Select the temperature control loop to edit before making any parameter changes. All parameters are only editable in USER and ADMIN levels.

Temperature Setpoint

The temperature setpoint is the desired temperature to control the gas generator hot zone.

Deviation Alarm (+/-)

The deviation alarm value determines when a temperature deviation alarm should be triggered.

Control Mode (Auto/Manual)

The control mode defines the PID control active status for the temperature control loop. Typically this parameter is left in "AUTO" mode but can be changed to "Manual" mode during initial system startup or for troubleshooting reasons. It should be fully understood that when the loop is in manual mode, the temperature is not under control and can go higher than desired. It is always recommended to check the over temperature controller (not included with EndoInjector™ system) prior to placing temperature PID in manual mode to ensure temperature will shut down if excessive temperature is reached.

Control Output (%)

The control output in the temperature setup panel is the same as the %output as detailed on the temperature detail panel on the main screen. The value is READ ONLY when temperature PID control is in AUTO mode. However, the %Output can be changed when PID is in MANUAL mode.

Control Setup (P) (Default = 2.0)

The proportional term delivers an output which is proportional to the size of the error signal. In simple terms, the larger the P value is the slower the temperature PID will respond to temperature changes.

Control Setup (I) (Default = 0.10)

The integral term removes steady state control offset by ramping the trim output up or down in proportion to the amplitude and duration of the error signal. This value must be set longer than the time constant of the temperature control process to avoid temperature oscillations. In simple terms, the larger the value the slower the temperature PID will respond to temperature changes.

Control Setup (D) (Default = 0.00)

The derivative term is proportional to the rate of change of the temperature value. It is used to prevent overshoot and undershoot of the setpoint by introducing an anticipatory action. In simple terms, generator temperature control will not typically require a D value.

Temperature Units (F or C)

The temperature units button will change the temperature measurements and calculation units. This change only occurs in the HMI and will not affect system control characteristics. However, the values stored in the history log files will change depending on this parameter.

TEMPERATURE SETUP PARAMETERS (USER and ADMIN Levels)

(CONTINUED FROM PREVIOUS PAGE)

Low Temp Alarm

The low temperature alarm is a critical safety setpoint. When the actual control temperature is higher than this value the low temperature alarm relay will energize. This relay must be wired into the motor start circuit for the EndoInjector™ mixing system so that if the temperature goes below this low temperature setpoint the mixing system must stop and the reaction gas must automatically be isolated. The minimum setpoint of this value shall be 1400degF per NFPA 86 guidelines.

Control Cycle Time (sec)

The control cycle time is used to setup time proportional control of the relay output used for temperature control. This time value represents the amount of time to divide between high fire and low fire based on the %output of the temperature control PID loop. The %output represents the % of the control cycle time to remain at high fire. For example, if the Control Cycle time was set to 20 seconds and the temperature control %output was 75% then the temperature control relay would remain energized 15 seconds and de-energized 5 seconds.

(THE REST OF THIS PAGE HAS BEEN LEFT BLANK)

SYSTEM SETUP PARAMETERS (ADMIN Level Only)

These parameters are used to setup the basic control design and communication requirements of the gas generator. Changes to these parameters will take effect immediately. All parameters are only editable in ADMIN level.

Enable Temp Loops

The enable temperature loops button is used to define how many individual temperature control PID loops will be enabled on the control system.

Air mA Offset (Default = 0.00)

The air mA offset button is used to offset the air transducer reading to “zero” the sensor readings when the EndoInjector mixing system is not running. Note that actual transducer mA readings are shown at the lower right corner of the system setup panel.

Gas mA Offset (Default = 0.00)

The gas mA offset button is used to offset the gas transducer reading to “zero” the sensor readings when the EndoInjector mixing system is not running. Note that actual transducer mA readings are shown at the lower right corner of the system setup panel.

Endo Expansion Factor (Default = 1.43)

The endothermic expansion factor is used to calculate the endothermic gas flow based on the air and gas flows currently measured. $ENDO\ FLOW = (AIR\ FLOW + GAS\ FLOW) \times (ENDO\ EXPANSION\ FACTOR)$

Endo Expansion Factor = 1.43 (Natural Gas Systems)

Endo Expansion Factor = 1.53 (Propane Gas Systems)

HMI Communication (Default = Serial)

The HMI communication button will toggle the desired communication port from Serial to TCP/IP. This parameter is used to setup the touch screen and inform what type of connection should be used to find the EndoInjector process controller.

HMI Serial Port (Default = COM1)

The HMI serial port button is used to setup what COM port the EndoInjector process controller will be attached to the touch screen when the HMI Communication is in “Serial” mode.

Ratio PCB Slave Port (Default = 485)

The ratio PCB slave port button is used to inform the EndoInjector™ process control what port on the PCB is attached to the dew point and temperature controller.

PCB IP Addr (Default = 192.168.0.225)

The PCB IP Address button is used to set the IP address for the main EndoInjector™ controller.

PCB IP Mask (Default = 255.255.255.0)

The PCB IP Address button is used to set the IP mask for the main EndoInjector™ controller.

Probe T/C Type (Default = S)

The probe T/C type button is used to setup the dew point controller input so that it is set correctly based on what type of thermocouple is in the zirconia probe.

SYSTEM SETUP PARAMETERS (ADMIN Level Only)

(CONTINUED FROM PREVIOUS PAGE)

Temp #| T/C Type (Default = K)

The temp #| T/C type button is used to setup the temperature controller input so that it is set correctly based on what type of thermocouple is on the gas generator. Note: Additional Temp# T/C Types are made available when multiple temperature control loops are enabled.

Set System Defaults

The set system defaults will reset the process controllers so that they return to factory settings. The generator should not be running when performing a “System Defaults”. Make note of all parameters before performing this as well.

(THE REST OF THIS PAGE HAS BEEN LEFT BLANK)

PAPERLESS CHART RECORDER

Pressing the “History” button on the main screen opens the EndoInjector paperless chart recorder. The paperless chart recorder displays the long term historical data for all generator process variables. Data is stored once every minute on the touch-screen hard drive in daily encrypted log files that can be exported to CSV files that can be opened in any spreadsheet program (i.e. MS Excel) for detailed investigation and reporting if required. The generator performance data will never overwrite old data since the hard drive space provides 50+ years worth of daily storage space. However, for tacking purposes, the data should only be considered archived for 5+ years on the touch screen unless backed up to a remotely maintained data storage center.

PAPERLESS CHART RECORDER OVERVIEW

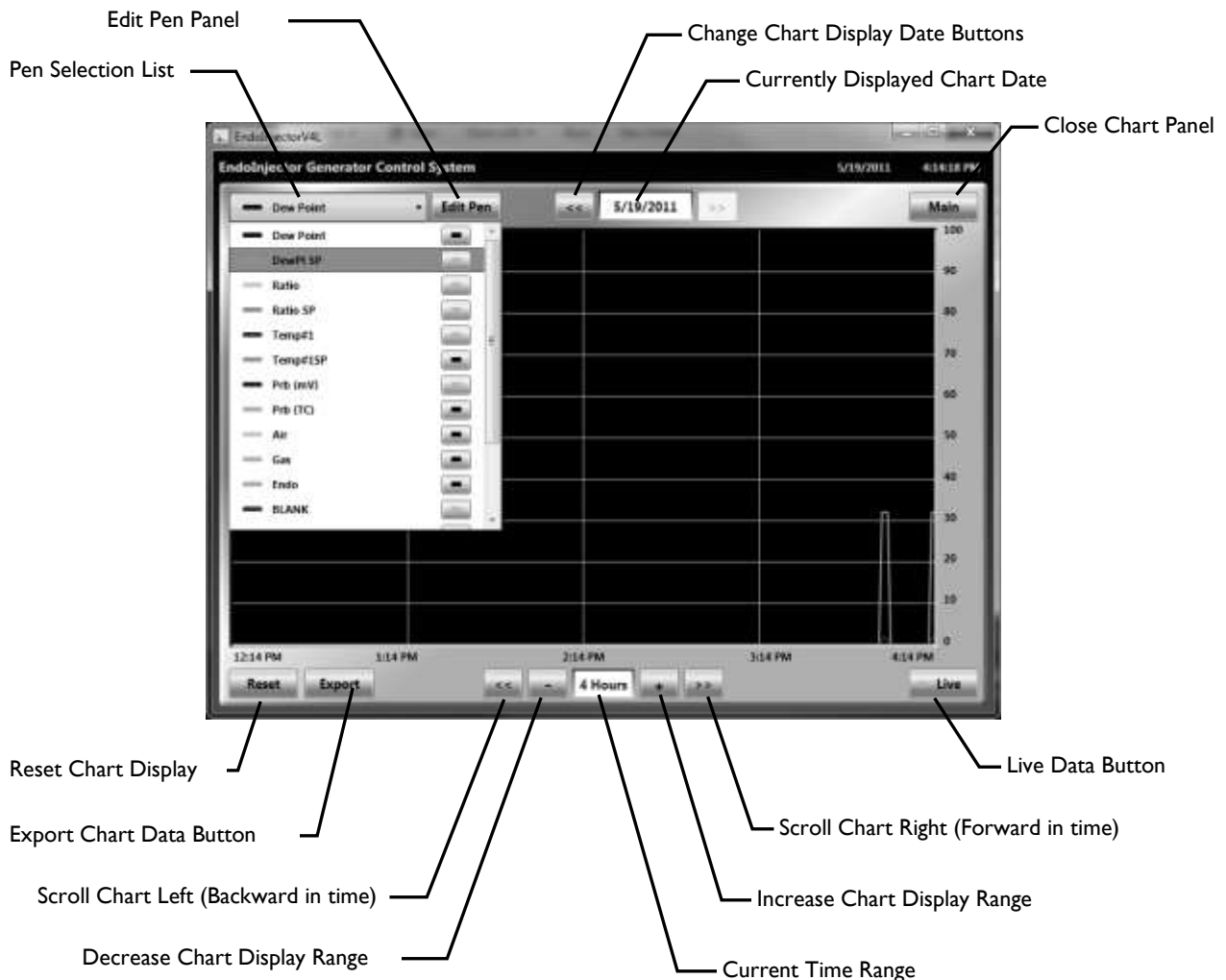

PAPERLESS CHART RECORDER

(CONTINUED FROM PREVIOUS PAGE)

PEN SELECTION LIST

The pen selection list provides a list of all pens available to display, the current pen color for each variable, and a button to display or hide the pen on the chart. Also, selecting a pen will update the scale values on the right of the chart to display the selected pen's scale settings. Each pen is drawn based on their own minimum and maximum scale range. The scale range for each pen can be changed by first selecting that pen in the Pen Selection List and then pressing the "Edit Pen" button. Note: The actual data values are stored regardless of pen scale or display settings.

Edit Pen Button

The edit pen button opens a panel that provides a way to edit the minimum display scale range, maximum display scale range, and pen color selection. Note that each pen is drawn based to it's own scale however, actual data stored is not affected by these settings.

Currently Displayed Chart Date

The log data is separated into daily log files. The log file that is currently being displayed is shown in the currently displayed chart date at the top of the chart.

Change Chart Display Date Buttons

The change chart display date buttons are located on either side of the current chart date at the top of the chart screen. Pressing these buttons will increase or decrease the current display date by one day.

Current Time Range

The current time range is found at the bottom of the chart display and represents the amount of time currently displayed from the left to the right on the chart. The default is to display 4 hours of data at a time but this can be increased to an entire day or decreased to just 15 minutes.

Increase / Decrease Chart Display Range Buttons (+ / -)

The increase and decrease chart display buttons will change the time range of data to display on the chart. Basically, these buttons provide a way to zoom in and out of the data in time. The limit is to increase the range to view an entire day of data or decrease the range to view just 15minutes of data.

Scroll Chart Right / Left (<< / >>)

The scroll chart buttons provide the means to pan the chart through time. Each press of either of these buttons will scroll the chart by 2 vertical gridlines (1/2 of the time range displayed).

Live Data Button

The live data button indicates and provides a way to turn the chart display on or off so that it automatically updates while viewing the data. When the live button is "on" then the chart will update and scroll automatically from right to left as new data is written to the log file.

Reset Chart Display

The reset chart display will reset the current display date to "today" and the current time range to 4 hours.

Export Data Button

The export data button opens a save dialog window to export the currently displayed daily data to a csv file. Attach a USB storage device to one of the USB ports on the back of the touch-screen then navigate and save the csv file to the storage device so that it can be transferred to another computer for review.

ALARM STATUS SCREEN

Pressing the “Status” button on the main screen opens the alarm status screen that indicates current system alarm status. The lists of alarms will turn green or red depending on status of the alarm being described. Red indicates an active alarm while green indicates that the alarm is OK.

Critical System Alarms

Critical alarms are determined to be critical for the safe operation of the generator. If any critical system alarm is detected it will release the critical alarm relay that shall be interlocked into the EndoInjector start circuit inside the generator control panel so that the mixing system and the reaction gas supply will automatically shut down.

Air Signal Status

If the air flow transducer is outside the normal 4-20mA range this will trigger an air signal status alarm. This is a critical alarm as the air signal is required for safe air gas mixture control.

Gas Signal Status

If the gas flow transducer is outside the normal 4-20mA range this will trigger an air signal status alarm. This is a critical alarm as the gas signal is required for safe air gas mixture control.

Low Retort Temperature

If the retort temperature is below the low temperature alarm setpoint (minimum setting is 1400degF) then per NFPA86 guidelines, the generator is not at a sufficient temperature to create endothermic gas. This can cause raw gas and air to be introduced into a furnace down stream. Therefore, this is considered a critical alarm that must shut down the mixing system.

Control TC Signal

If the control thermocouple is not connected or an open loop is detected then it will be impossible to determine the actual temperature inside the generator. Therefore, this is a critical alarm that must shut down the mixing system.

High Ratio Alarm

If the air/gas ratio is over the high ratio alarm setpoint for a time longer than the high ratio alarm delay time then a high ratio alarm is triggered. This can occur when the gas supply is not adequate to maintain enough supply to the mixing system or the fuel-injection control valve is not responding. In either event, this is considered a critical system alarm and must shut down the mixing system before an unsafe situation can occur.

Non-Critical System Alarms

Non-Critical alarms are determined not to be critical for the safe operation of the generator but should provide warning to operators when generator control is outside recommended limits.

Ratio Deviation

A ratio deviation alarm occurs when the actual air/gas ratio has deviated from the ratio setpoint by more than the ratio deviation alarm setting. There is a 30 second time delay on this alarm to minimize the occurrence of nuisance alarms.

Dew Point Deviation

A dew point deviation alarm occurs when the actual dew point has deviated from the dew point setpoint by more than the dew point deviation alarm setting. There is a 60 second time delay on this alarm to minimize the occurrence of nuisance alarms.

Temperature Deviation

A temperature deviation alarm occurs when the actual temperature has deviated from the temperature setpoint by more than the temperature deviation alarm setting. There is a 60 second time delay on this alarm to minimize the occurrence of nuisance alarms.

Probe Signal

A probe signal alarm occurs if either the probe mV signal or probe thermocouple signal are outside normal operating range and cannot accurately calculate actual gas dew point. This alarm typically will occur when the probe is cold or during heat up. Also, the alarm can occur intermittently when the endo sample is not high enough to maintain a consistent sample of gas to the probe.

Communication Alarms

COM alarms occur when any failure of the Modbus communication is detected.

Port Open

A port open alarm occurs when the com port selected in the setup screen is not actually found on the HMI touch screen. Also, if the communication port of Ethernet is selected then a port alarm will occur when the IP address the HMI is trying to reach to communicate with the ratio controller is not found.

Ratio Controller

A ratio controller communication alarm occurs when the ratio controller cannot be found or a Modbus read or write operation has failed. Typically, this alarm will occur if the polarity of a serial connection is reversed or disconnected.

Process Controller

A process controller communication alarm occurs when the ratio control PCB cannot communicate with the dew point and temperature controller. It should be understood that the dew point and temperature controller is a slave instrument of the main ratio control PCB. This alarm typically occurs if the selected PCB Slave port is not selected correctly in the System Setup screen (typically should be set to 485) or the polarity of the wiring between the PCB and process controller is reversed or disconnected.

Maintenance

The LP EndoInjector™ is designed as a very robust industrial mixing system and the control logic is setup to monitor critical system faults before damage can occur. However, there are a few recommended items to check regularly on the mixing system to ensure successful system operation over many years.

Intake Air Filter

The intake air filter is the main item of concern that must be checked regularly and changed preemptively to ensure that the blower motor is not overheated or damaged. Atmosphere Engineering installs a filter change indicator next to the intake air filter that should be inspected weekly and when the filter change indicator reaches the “RED ZONE” then the filter element should be removed, blown off/cleaned, and then replaced. After resetting the filter change indicator, continue to watch the filter change indicator. If the filter change indicator reaches the “RED ZONE” again then the filter element should be changed. Filter change times will range between monthly to every 6 months depending on the air quality in the room where the EndoInjector is located. In some circumstances, it may be advisable to pipe the incoming air from a separate location.

NOTICE

Running the blower with the filter change indicator in the “RED ZONE” for an extended period can cause offset in flow transducer readings and will cause the blower to overheat and can cause damage to the blower bearings and motor.

(THE REST OF THIS PAGE HAS BEEN LEFT BLANK)